

**RT21**

**(A421)**

## RT21

Location of Unit . . . . .	3
1. Exterior and Drive Section (A421) . . . . .	4
2. Tray Section (A421) . . . . .	6
3. Tray Main Board (A421) . . . . .	8
4. Harness Layout (A421) . . . . .	10
5. Main DC Harness (A421) . . . . .	12
6. AC Harness (A421) . . . . .	14
7. Tray DC Harness (A421) . . . . .	16
8. Decal (A421) . . . . .	18
Parts Index . . . . .	21

1. EXTERIOR AND DRIVE SECTION

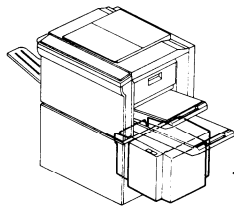

2. TRAY SECTION

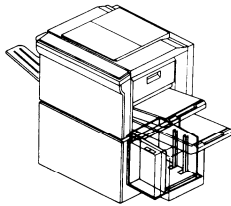

# 1. EXTERIOR AND DRIVE SECTION (A421)

August 31, '89

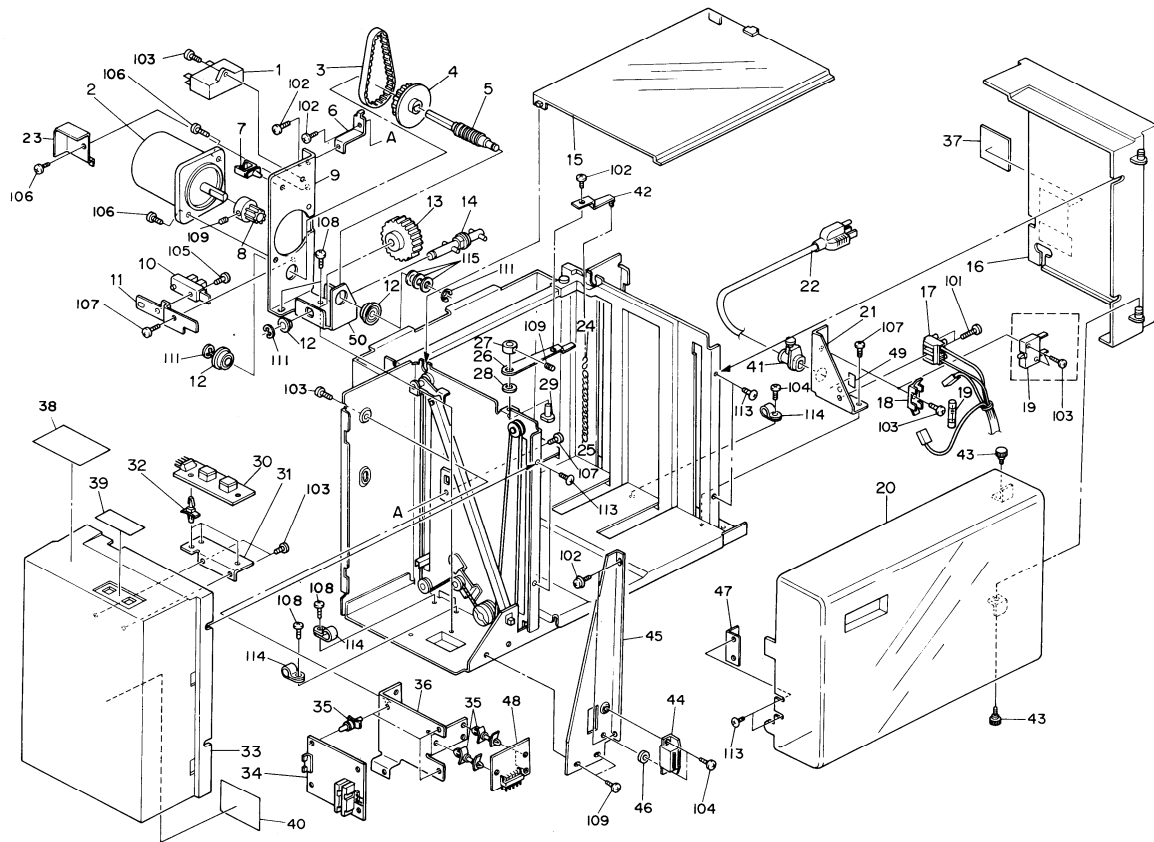



## 2. TRAY SECTION (A421)

August 31, '89

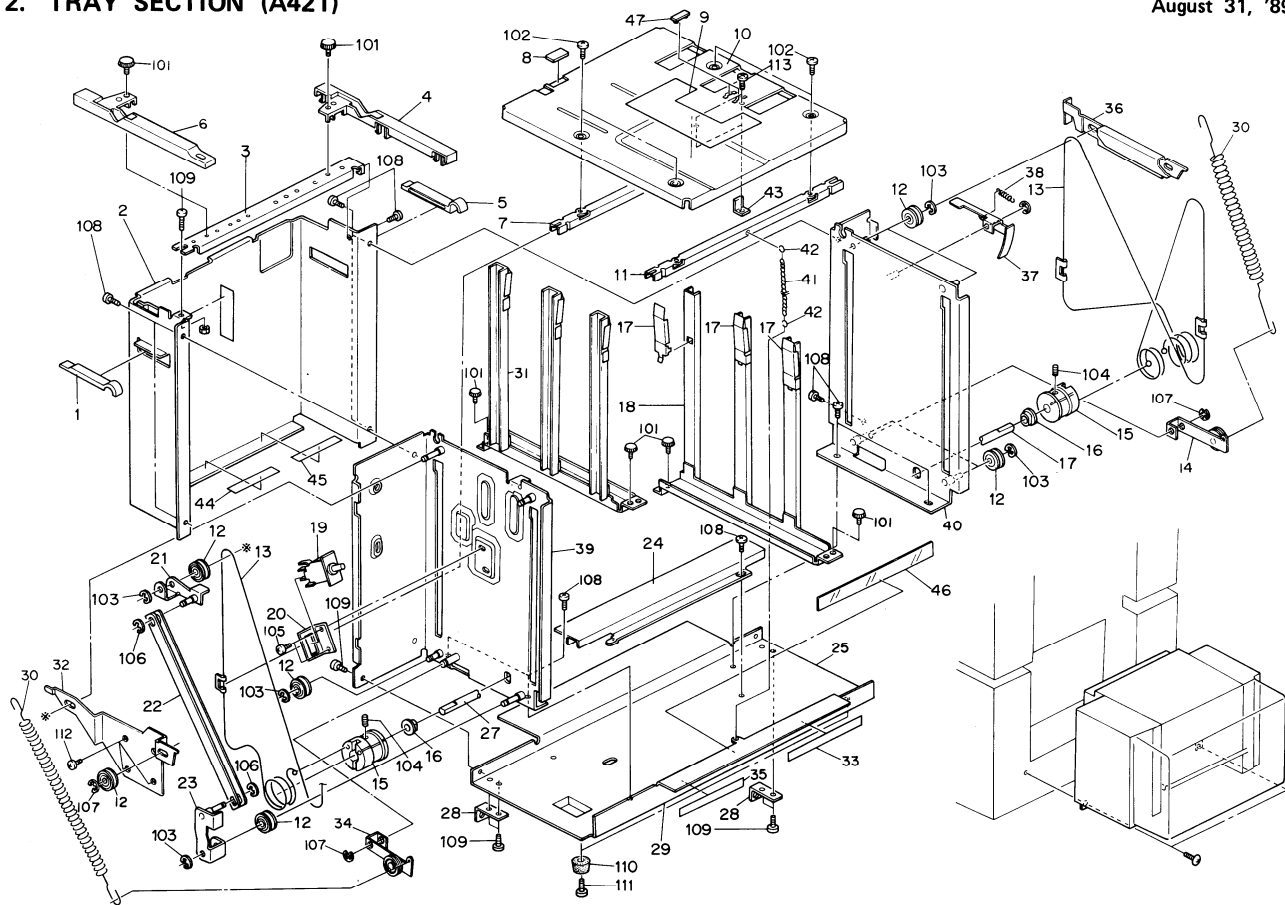

## 2. TRAY SECTION (A421)

August 31, '89

Index No.	Part No.	Description	Q'ty Per Assembly
1	A421 2530	Front Guide Rail	1
2	A421 2525	Couple Bracket	1
3	A421 2535	Paper Size Stay	1
4	A421 2554	Side Post Grip	1
5	A421 2531	Front Guide Rail	1
6	A421 2548	Side Post Grip	1
7	A403 1239	Left Lift Rod	1
8	A421 2543	Friction Rad - B	1
9	A421 1275	Decal - Paper Size	1
10	A421 2540	Tray Bottom Plate	1
11	A403 1238	Right Lift Rod	1
12	5446 2620	Idler Pulley - 20	8
13	AA05 0006	Drive Wire	2
14	A403 1145	Rear Wire Tightener	1
15	AB03 2005	Rack Drive Shaft Pulley	2
16	5053 0419	Bushing - 10mm - Long - 7mm	2
17	A421 2553	Size Post Rack - Spring Plate	3
18	A421 2550	Size Post Rack	1
19	1204 1280	Push Switch	1
20	A403 1166	Safety Switch Bracket	1
21	A403 1172	Top Actuator Lever	1
22	A403 1171	Safety Switch Actuator	1
23	A403 1174	Bottom Actuator Lever	1
24	A403 1103	Harness Cover	1
25	A421 2501	Tray Bottom Plate	1
26	A421 2505	Set Angle	2
27	AA14 0027	Rack Drive Shaft	1
28	A000 2824	Tape	2
29	A403 1183	Paper Detect Shaft	1
30	AA06 0028	Spring	2
31	A421 2545	Size Post Rack	1
32	A403 1186	Support Bracket	1
33	A421 2510	Rear Paper Size Decal	1
34	A403 1143	Front Wire Tightener	1
35	A421 2508	Front Paper Size Decal	1

Index No.	Part No.	Description	Q'ty Per Assembly
36	A403 1187	Rear Support Plate	1
37	A421 2520	Actuator - Paper Volume	1
38	A421 2521	Spring - Paper Volume	1
39	A403 1111	Front Side Frame	1
40	A421 2515	Rear Side Frame	1
41	A403 1147	Chain	1
42	5925 2259	Hook	2
43	A403 1148	Back Fence	1
44	A421 2527	Front Paper Size Decal - Left	1
45	A421 2528	Rear Paper Size Decal - Left	1
46	5920 1511	Mylar - 100x19mm	1
47	A421 2539	Hole Cover	4
101	0803 0017	Knob Screw	
102	0313 0040W	Philips Pan Head Screw - M3x4	
103	0720 0040E	Retaining Ring - M4	
104	0575 0050E	Hexagon Headless Set Screw - M5x5	
105	0314 0050W	Philips Pan Head Screw - M4x5	
106	0720 0030E	Retaining Ring - M3	
107	0720 0060E	Retaining Ring - M6	
108	0434 0080W	Tapping Screw - M4x8	
109	0434 0060W	Tapping Screw - M4x6	
110	0770 0432	Rubber Shoe	
111	0314 0200W	Philips Pan Head Screw - M4x20	
112	0314 0040W	Philips Pan Head Screw - M4x4	
113	0951 4006W	Philips Screw With Flat Washer - M4x6	

### 3. TRAY MAIN BOARD (A421)

August 31, '89

#### CONNECTER

SYMBOL NO.	INDEX NO.
CN100	105
CN101	104
CN102	102
CN103	103
CN104	101
CN105	106

#### SSR

SYMBOL NO.	INDEX NO.
SSR100	107
SSR101	107

#### TRANSISTOR

SYMBOL NO.	INDEX NO.
Q100	108
Q101	109
Q102	108
Q103	109

#### DIODE

SYMBOL NO.	INDEX NO.
D100	110
D101	110
D102	110
D103	110
D104	110
D105	110
D106	110
D107	110

#### IC

SYMBOL NO.	INDEX NO.
IC100	115
IC101	113
IC102	111
IC103	112
IC104	111
IC105	114
IC106	116

#### CAPACITOR

SYMBOL NO.	INDEX NO.
C100	117
C101	120
C102	119
C103	118
C104	118
C105	118
C106	119
C107	120
C108	120
C109	120

#### RESISTOR

SYMBOL NO.	INDEX NO.
R100	123
R101	124
R102	123
R103	130
R104	124
R105	122
R106	123
R107	129
R108	123
R109	122

SYMBOL NO.	INDEX NO.
R110	122
R111	123
R112	123
R113	123
R114	123
R115	122
R116	124
R117	129
R118	125
R119	123

SYMBOL NO.	INDEX NO.
R120	122
R121	127
R122	128
R123	124
R124	127
R125	122
R126	124
R127	129
R128	127
R130	123

SYMBOL NO.	INDEX NO.
R131	122
R132	127
R133	122
R134	126
R135	127
R136	131
R138	124



### 3. TRAY MAIN BOARD (A421)

August 31, '89

Index No.	Part No.	Description	Q'ty Per Assembly
*	A421 5200	Tray Main Board	1

Index No.	Part No.	Description	Q'ty Per Assembly
101	1103 1247	Connector - 3P	
102	1103 1729	Connector - 7P	
103	1103 1730	Connector - 8P	
104	1103 1739	Connector - 3P	
105	1103 1743	Connector - 7P	
106	1103 1757	Connector - 7P	
107	1208 1047	Solid State Relay - 240V/3A	
108	1400 0072	Transistor - 2SC372Y	
109	1400 0135	Transistor - 2SA1015-Y	
110	1401 0825	Diode - 1SS176	
111	1407 0520	IC - HD74LS00	
112	1407 0622	IC - HD74LS10P	
113	1407 0981	IC - TD62503P	
114	1407 2028	IC - SN74LS06N	
115	1408 0124	IC - LM555CN	
116	1408 0412	IC - 7705CP	
117	1604 0909	Capacitor - 1 $\mu$ F 50V	
118	1604 1363	Capacitor - 10 $\mu$ F 25V	
119	1604 1366	Capacitor - 47 $\mu$ F 25V	
120	1606 1336	Capacitor - 1000 $\mu$ F 50V	
121	1606 1458	Capacitor - 0.1 $\mu$ F 50V	
122	1611 4101V	Resistor - 1KOHM 1/4W $\pm$ 5%	
123	1611 4102V	Resistor - 1KOHM 1/4W $\pm$ 5%	
124	1611 4103V	Resistor - 10KOHM 1/4T $\pm$ 5%	
125	1611 4104V	Resistor - 100KOHM 1/4V $\pm$ 5%	
126	1611 4380V	Resistor - 380OHM 1/4W $\pm$ 5%	
127	1611 4771V	Resistor - 470OHM 1/4W $\pm$ 5%	
128	1611 4472V	Resistor - 4.7KOHM 1/4T $\pm$ 5%	
129	1611 4562V	Resistor - 5.6KOHM 1/4W	
130	1611 4564V	Resistor - 560KOHM 1/4W	
131	1611 4680V	Resistor - 680OHM 1/4W $\pm$ 5%	

#### 4. HARNESS LAYOUT (A421)

August 31, '89

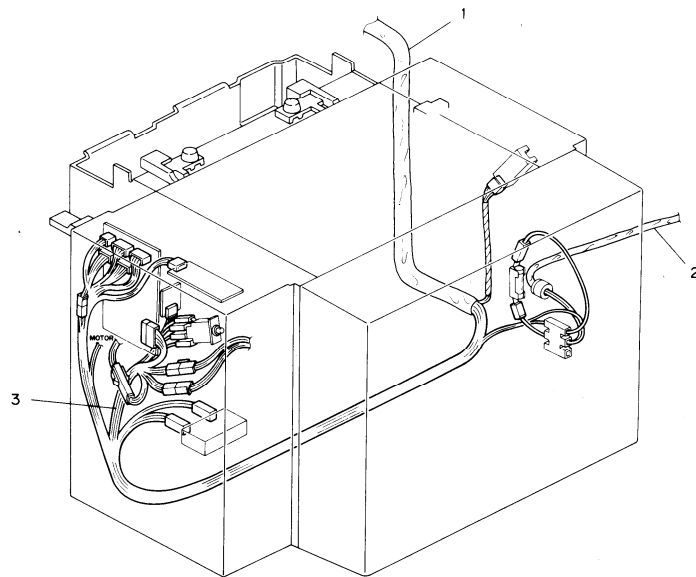

#### 4. HARNESS LAYOUT (A421)

August 31, '89

Index No.	Part No.	Description	Q'ty Per Assembly
1	A421 5340	Main DC Harness	1
2	A421 5300	AC Harness - 115V	1
2	A421 5310	AC Harness - 220V	1
3	A421 5330	Tray DC Harness	1

Index No.	Part No.	Description	Q'ty Per Assembly

# 5. MAIN DC HARNESS (A421)

August 31, '89

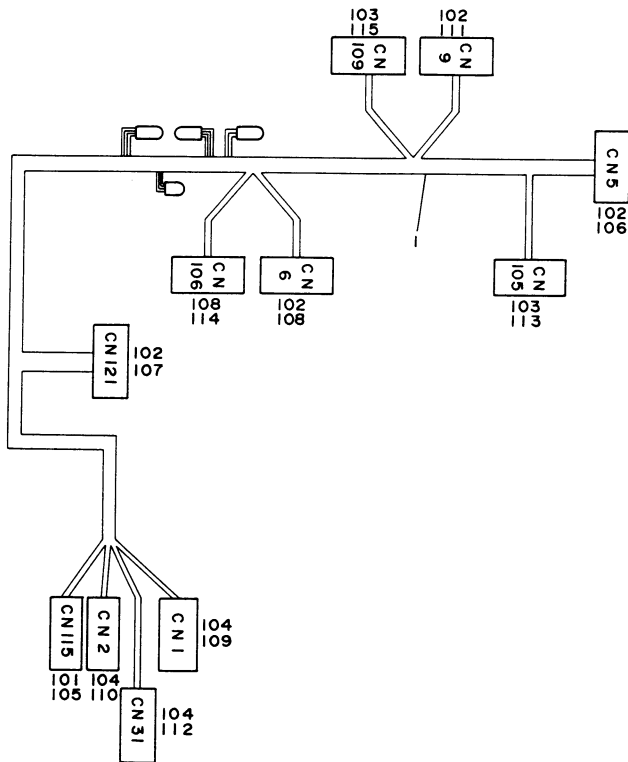

## 5. MAIN DC HARNESS (A421)

August 31, '89

Index No.	Part No.	Description	Q'ty Per Assembly
1	A421 5340	Main DC Harness	1

Index No.	Part No.	Description	Q'ty Per Assembly
101	1100 1238	Pin - Mate-N-Lock	
102	1100 1249	Receptacle Terminal	
103	1100 1253	Pin - Mate-N-Lock	
104	1100 1327	Contact	
105	1102 1506	Pin Housing - Mate-N-Lock - 10P	
106	1102 1621	Receptacle Housing - 3P	
107	1102 1623	Receptacle Housing - 7P	
108	1102 1625	Receptacle Housing - 10P	
109	1102 1929	Connector - 7P	
110	1102 1925	Connector - 3P	
111	1102 1784	Connector - 12P	
112	1102 1943	Receptacle Housing	
113	1102 1661	Receptacle Housing - 4P	
114	1102 1778	Connector - 4P	
115	1102 1779	Connector - 12P	

# 6. AC HARNESS (A421)

August 31, '89

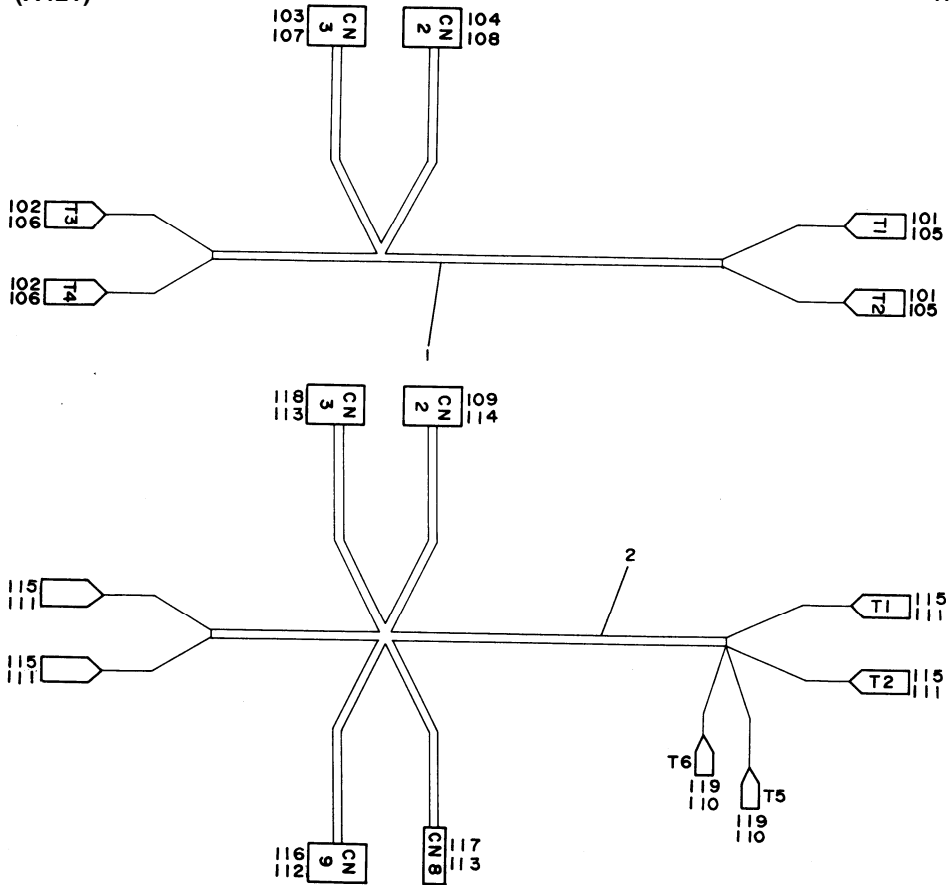

## 6. AC HARNESS (A421)

August 31, '89

Index No.	Part No.	Description	Q'ty Per Assembly
1	A421 5300	AC Harness - 115V	1
2	A421 5310	AC Harness - 220V	1

Index No.	Part No.	Description	Q'ty Per Assembly
101	1100 0277	Fastening Receptacle	
102	1100 1172	Fastening Receptacle	
103	1100 1241	Socket - Mate-N-Lock	
104	1100 1247	Terminal	
105	1102 0796	Connecting Sleeve 3.0mm - 220V	
106	1102 1404	Receptacle Housing	
107	1102 1516	Connector - 3P	
108	1102 1815	Connector - 3P	
109	1102 1815	Connector - 3P	
110	1100 0885	Fastening Receptacle	
111	1100 1172	Fastening Receptacle	
112	1100 1239	Pin - Mate-N-Lock	
113	1100 1241	Socket - Mate-N-Lock	
114	1100 1247	Terminal	
115	1100 1404	Receptacle Sleeve	
116	1102 1507	Connector - 2P	
117	1102 1514	Connector - 1P	
118	1102 1516	Connector - 3P	
119	1102 1745	Receptacle Sleeve	

# 7. TRAY DC HARNESS (A421)

August 31, '89

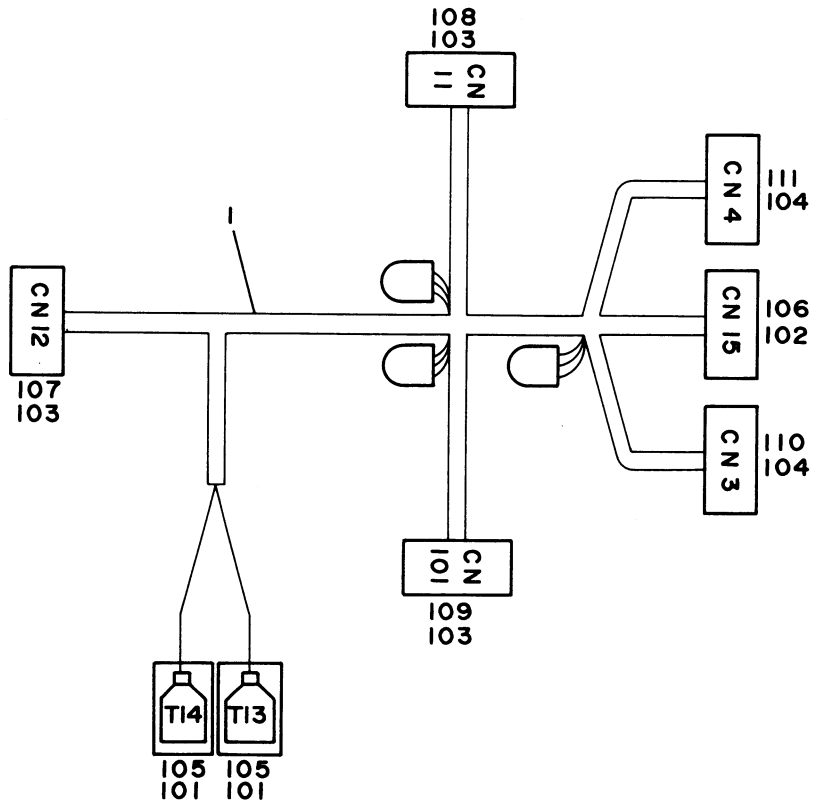



## 7. TRAY DC HARNESS (A421)

August 31, '89

Index No.	Part No.	Description	Q'ty Per Assembly
1	A421 5330	Tray DC Harness	1

Index No.	Part No.	Description	Q'ty Per Assembly
101	1100 1192	Receptacle Housing	
102	1100 1240	Socket - Mate-N-Lock	
103	1100 1249	Receptacle Terminal	
104	1100 1327	Contact	
105	1102 1404	Receptacle Housing	
106	1102 1514	Connector - 1P	
107	1102 1620	Connector - 3P	
108	1102 1621	Receptacle Housing - 3P	
109	1102 1623	Receptacle Housing - 7P	
110	1102 1915	Connector - 7P	
111	1102 1916	Connector - 8P	

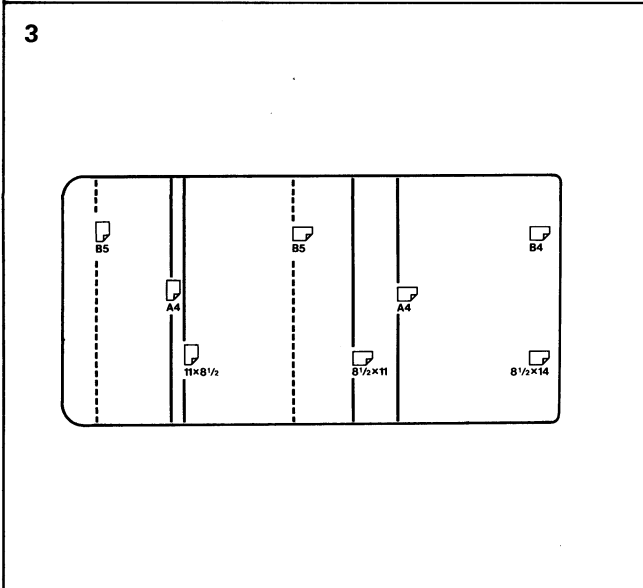
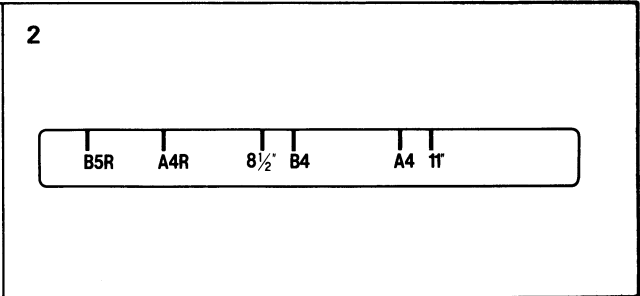
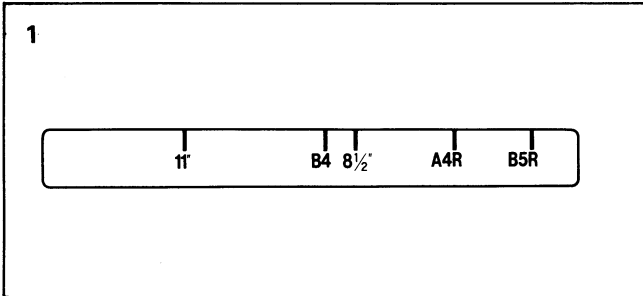

4

		0—OFF		1—ON			
DIP SW.		1	2	3	4	5	6
サイズ							
B4		0	0	0	1	1	0
A4		0	0	1	0	0	0
A4R		0	0	1	0	1	0
B5		0	0	1	1	0	0
B5R		0	0	1	1	1	0
11" × 8 1/2"		1	0	0	0	1	0
8 1/2" × 11"		1	0	1	1	0	0
8 1/2" × 14"		1	0	1	0	0	0

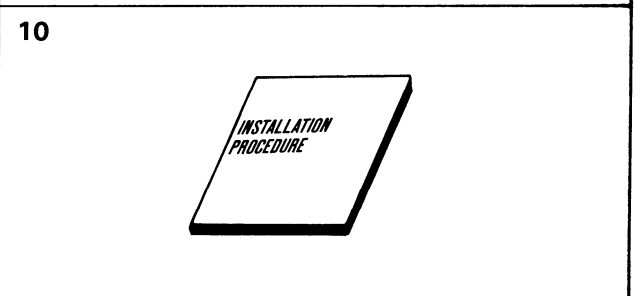
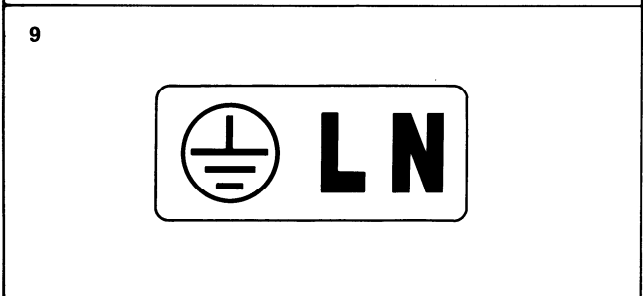
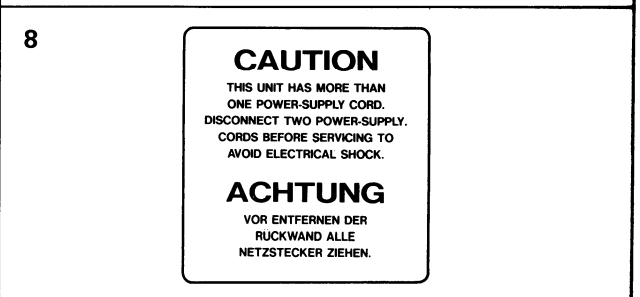
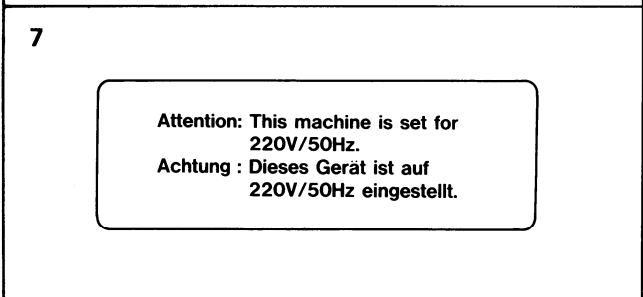
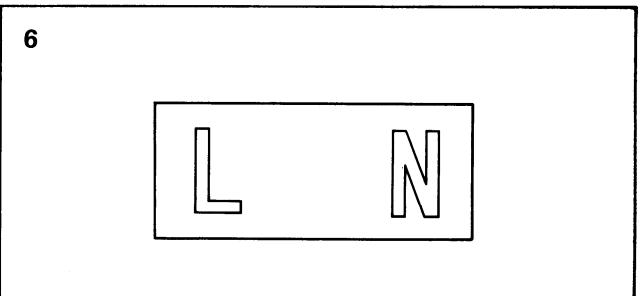
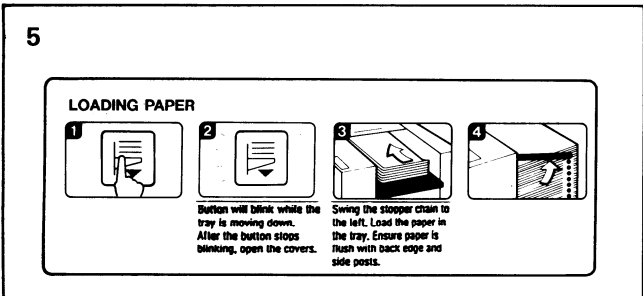

## 8. DECAL (A421)

August 31, '89

Index No.	Part No.	Description	Q'ty Per Assembly
1	A421 2508	Front Paper Size Decal	1
2	A421 2510	Rear Paper Size Decal	1
3	A421 1275	Decal - Paper Size	1
4	A421 2576	Decal - Paper Size	1
5	A421 2575	Decal - Operater Instruction	1
6	5403 4335	Decal - Terminal - 115V	1
7	5442 1372	Decal - Power Source - 220V	1
8	5446 8906	Decal - English , German - 220V	1
9	5447 4980	Decal - Terminal - 220V	1
10	A421 8610	Installation Procedure - English	1
10	A421 8615	Installation Procedure - 5 Language	1

Index No.	Part No.	Description	Q'ty Per Assembly
-----------	----------	-------------	-------------------

# **PARTS INDEX**

Parts No.	Description	Page and Index No.
A421 1275	Decal - Paper Size	19-3
A421 1275	Decal - Paper Size	7-9
A421 2501	Tray Bottom Plate	7-25
A421 2505	Set Angle	7-26
A421 2508	Front Paper Size Decal	19-1
A421 2508	Front Paper Size Decal	7-35
A421 2510	Rear Paper Size Decal	19-2
A421 2510	Rear Paper Size Decal	7-33
A421 2515	Rear Side Frame	7-40
A421 2520	Actuator - Paper Volume	7-37
A421 2521	Spring - Paper Volume	7-38
A421 2525	Couple Bracket	7-2
A421 2527	Front Paper Size Decal - Left	7-44
A421 2528	Rear Paper Size Decal - Left	7-45
A421 2530	Front Guide Rail	7-1
A421 2531	Front Guide Rail	7-5
A421 2535	Paper Size Stay	7-3
A421 2539	Hole Cover	7-47
A421 2540	Tray Bottom Plate	7-10
A421 2543	Friction Rad - B	7-8
A421 2545	Size Post Rack	7-31
A421 2548	Side Post Grip	7-6
A421 2550	Size Post Rack	7-18
A421 2553	Size Post Rack - Spring Plate	7-17
A421 2554	Side Post Grip	7-4
A421 2561	Tray Main Board Bracket	5-36
A421 2570	Bracket - Cover Plate (115V)	5-23
A421 2575	Decal - Operator Instruction	19-5
A421 2575	Decal - Operator Instruction	5-38
A421 2576	Decal - Paper Size	19-4
A421 2576	Decal - Paper Size	5-40
A421 2580	Front Cover	5-33
A421 2590	Rear Cover	5-16
A421 2600	Side Cover	5-20
A421 2610	Top Cover	5-15

Parts No.	Description	Page and Index No.
A421 5100	Paper Size Board	5-48
A421 5200	Tray Main Board	5-34
A421 5200	Tray Main Board	9-*
A421 5300	AC Harness - 115V	11-2
A421 5300	AC Harness - 115V	15-1
A421 5310	AC Harness - 220V	11-2
A421 5310	AC Harness - 220V	15-2
A421 5330	Tray DC Harness	11-3
A421 5330	Tray DC Harness	17-1
A421 5340	Main DC Harness	11-1
A421 5340	Main DC Harness	13-1
A421 8610	Installation Procedure - English	19-10
A421 8615	Installation Procedure - 5 Language	19-10

Parts No.	Description	Page and Index No.
AA04 0004	Timing Belt - 120XL-037	5-3
AA05 0006	Drive Wire	7-13
AA06 0028	Spring	7-30
AA14 0027	Rack Drive Shaft	7-27
AB01 3045	Worm Gear	5-5
AB01 3046	Gear - 45T	5-13
AB03 0007	Pulley - 10T	5-8
AB03 0008	Pulley - 20T	5-4
AB03 2005	Rack Drive Shaft Pulley	7-15
AX02 0007	Tray Drive Motor - AC35V	5-2
AX02 0008	Tray Drive Motor - AC35V	5-2
A000 2824	Tape	7-28
A403 1103	Harness Cover	7-24
A403 1111	Front Side Frame	7-39
A403 1117	Front AID Plate	5-45
A403 1118	Magnet Collar	5-46
A403 1123	Stopper Bar	5-26
A403 1124	Spring Plate - Stopper Bar	5-42
A403 1125	Stopper Bar Knob	5-29
A403 1126	Stopper Bar Mounting Stud	5-27
A403 1143	Front Wire Tightener	7-34
A403 1145	Rear Wire Tightener	7-14
A403 1147	Chain	7-41
A403 1148	Back Fence	7-43
A403 1166	Safety Switch Bracket	7-20
A403 1167	Clamp Stay	5-6
A403 1168	Sensor Bracket	5-11
A403 1171	Safety Switch Actuator	7-22
A403 1172	Top Actuator Lever	7-21
A403 1174	Bottom Actuator Lever	7-23
A403 1181	Drive Motor Bracket	5-9
A403 1182	Motor Bracket	5-50
A403 1183	Paper Detect Shaft	7-29
A403 1186	Support Bracket	7-32
A403 1187	Rear Support Plate	7-36

Parts No.	Description	Page and Index No.
A403 1188	Drive Shaft	5-14
A403 1238	Right Lift Rod	7-11
A403 1239	Left Lift Rod	7-7
A403 1245	Magnet Catch Plate	5-47
A403 5502	Fuse - 250V 2A	5-19
A912 2596	Operation Skin	5-39
A912 5010	Operation Board	5-30
5053 0419	Bushing - 10mm - Long - 7mm	7-16
5054 0536	Magnet Catch Ass'y	5-44
5205 5250	LED Sensor - Type S	5-10
5304 1639	Bushing - 8mm	5-12
5403 4335	Decal - Terminal - 115V	19-6
5403 4335	Decal - Terminal - 115V	5-49
5408 7968	Power Supply Cord - 220V	5-22
5419 5714	Stepped Screw - M4	5-43
5442 1372	Decal - Power Source - 220V	19-7
5442 1372	Decal - Power Source - 220V	5-37
5443 2713	Wave Washer	5-28
5446 2620	Idler Pulley - 20	7-12
5446 8906	Decal - English , German - 220V	19-8
5446 8906	Decal - English , German - 220V	5-37
5447 4980	Decal - Terminal - 220V	19-9
5447 4980	Decal - Terminal - 220V	5-49
5897 1272	Operation Board Mounting Bracket	5-31
5897 1488	Hook	5-24
5897 1490	Stopper Chain	5-25
5920 1511	Mylar - 100x19mm	7-46
5925 2259	Hook	7-42
5925 2266	Power Cord Bracket	5-21
6769 7930	Power Supply Cord - 115V	5-22

Parts No.	Description	Page and Index No.
0313 0040W	Philips Pan Head Screw - M3x4	7-102
0313 0140W	Philips Pan Head Screw - M3x14	5-101
0314 0040W	Philips Pan Head Screw - M4x4	5-102
0314 0040W	Philips Pan Head Screw - M4x4	7-112
0314 0050W	Philips Pan Head Screw - M4x5	7-105
0314 0060W	Philips Pan Head Screw - M4x6	5-103
0314 0080W	Philips Pan Head Screw - M4x8	5-104
0314 0100W	Philips Pan Head Screw - M4x10	5-105
0314 0200W	Philips Pan Head Screw - M4x20	7-111
0315 0120W	Philips Pan Head Screw - M5x12	5-106
0434 0060W	Tapping Screw - M4x6	5-107
0434 0060W	Tapping Screw - M4x6	7-109
0434 0080W	Tapping Screw - M4x8	5-108
0434 0080W	Tapping Screw - M4x8	7-108
0575 0050E	Hexagon Headless Set Screw - M5x5	5-109
0575 0050E	Hexagon Headless Set Screw - M5x5	7-104
0700 0060B	Washer - 6mm	5-110
0700 0080E	Washer - 8mm	5-115
0720 0030E	Retaining Ring - M3	7-106
0720 0040E	Retaining Ring - M4	7-103
0720 0060E	Retaining Ring - M6	5-111
0720 0060E	Retaining Ring - M6	7-107
0770 0432	Rubber Shoe	7-110
0801 1185	Philips Truss Head Screw - M4x8	5-112
0802 5094	Tapping Screw - M4x8	5-113
0803 0017	Knob Screw	7-101
0951 4006W	Philips Screw With Flat Washer - M4x6	7-113
1100 0277	Fastening Receptacle	15-101
1100 0885	Fastening Receptacle	15-110
1100 1172	Fastening Receptacle	15-102
1100 1172	Fastening Receptacle	15-111
1100 1192	Receptacle Housing	17-101
1100 1238	Pin - Mate-N-Lock	13-101
1100 1239	Pin - Mate-N-Lock	15-112
1100 1240	Socket - Mate-N-Lock	17-102

Parts No.	Description	Page and Index No.
1100 1241	Socket - Mate-N-Lock	15-103
1100 1241	Socket - Mate-N-Lock	15-113
1100 1247	Terminal	15-104
1100 1247	Terminal	15-114
1100 1249	Receptacle Terminal	13-102
1100 1249	Receptacle Terminal	17-103
1100 1253	Pin - Mate-N-Lock	13-103
1100 1327	Contact	13-104
1100 1327	Contact	17-104
1100 1404	Receptacle Sleeve	15-115
1101 0359	Terminal - 3P	5-17
1102 0796	Connecting Sleeve 3.0mm - 220V	15-105
1102 0895	Nylon Stud	5-32
1102 1404	Receptacle Housing	15-106
1102 1404	Receptacle Housing	17-105
1102 1506	Pin Housing - Mate-N-Lock - 10P	13-105
1102 1507	Connector - 2P	15-116
1102 1514	Connector - 1P	15-117
1102 1514	Connector - 1P	17-106
1102 1516	Connector - 3P	15-107
1102 1516	Connector - 3P	15-118
1102 1620	Connector - 3P	17-107
1102 1621	Receptacle Housing - 3P	13-106
1102 1621	Receptacle Housing - 3P	17-108
1102 1623	Receptacle Housing - 7P	13-107
1102 1623	Receptacle Housing - 7P	17-109
1102 1625	Receptacle Housing - 10P	13-108
1102 1661	Receptacle Housing - 4P	13-113
1102 1745	Receptacle Sleeve	15-119
1102 1778	Connector - 4P	13-114
1102 1779	Connector - 12P	13-115
1102 1784	Connector - 12P	13-111
1102 1815	Connector - 3P	15-108
1102 1815	Connector - 3P	15-109
1102 1915	Connector - 7P	17-110

Parts No.	Description	Page and Index No.
1102 1916	Connector - 8P	17-111
1102 1925	Connector - 3P	13-110
1102 1929	Connector - 7P	13-109
1102 1943	Receptacle Housing	13-112
1103 1247	Connector - 3P	9-101
1103 1729	Connector - 7P	9-102
1103 1730	Connector - 8P	9-103
1103 1739	Connector - 3P	9-104
1103 1743	Connector - 7P	9-105
1103 1757	Connector - 7P	9-106
1104 0322	Fuse Holder	5-18
1105 0016	Nylon Clip - 4N	5-114
1105 0108	Nylon Clip	5-7
1106 0336	Nylon Stud	5-35
1106 0442	Cord Clamp - 220/240V	5-41
1107 0487	Circuit Breaker - 115V	5-19
1204 1280	Push Switch	7-19
1208 1047	Solid State Relay - 240V/3A	9-107
1400 0072	Transistor - 2SC372Y	9-108
1400 0135	Transistor - 2SA1015-Y	9-109
1401 0825	Diode - 1SS176	9-110
1407 0520	IC - HD74LS00	9-111
1407 0622	IC - HD74LS10P	9-112
1407 0981	IC - TD62503P	9-113
1407 2028	IC - SN74LS06N	9-114
1408 0124	IC - LM555CN	9-115
1408 0412	IC - 7705CP	9-116
1604 0909	Capacitor - 1 $\mu$ F 50V	9-117
1604 1363	Capacitor - 10 $\mu$ F 25V	9-118
1604 1366	Capacitor - 47 $\mu$ F 25V	9-119
1606 1246	Capacitor - 9 $\mu$ F 250V	5-1
1606 1336	Capacitor - 1000 $\mu$ F 50V	9-120
1606 1458	Capacitor - 0.1 $\mu$ F 50V	9-121
1611 4101V	Resistor - 1KOHM 1/4W $\pm$ 5%	9-122
1611 4102V	Resistor - 1KOHM 1/4W $\pm$ 5%	9-123

Parts No.	Description	Page and Index No.
1611 4103V	Resistor - 10KOHM 1/4T $\pm$ 5%	9-124
1611 4104V	Resistor - 100KOHM 1/4W $\pm$ 5%	9-125
1611 4380V	Resistor - 380OHM 1/4W $\pm$ 5%	9-126
1611 4472V	Resistor - 4.7KOHM 1/4T $\pm$ 5%	9-128
1611 4562V	Resistor - 5.6KOHM 1/4W	9-129
1611 4564V	Resistor - 560KOHM 1/4W	9-130
1611 4680V	Resistor - 680OHM 1/4W $\pm$ 5%	9-131
1611 4771V	Resistor - 470OHM 1/4W $\pm$ 5%	9-127